

# Waste bin 120l Premium Series



## TECHNICAL DATA:

**Volume:** 120 lt  
**Dimensions:** 550 x 480 x 964 mm  
**Weight:** approx. 9,00 kg  
**Material:** HDPE, UV-stabilized, resistant to high and low temperatures  
**Wheels:** 2 rubber wheels Ø200  
Corrosion-free steel axle  
Foot board  
Reinforced comb receiver (honey-comb structure)  
Additional reinforcement on all walls – form of curved surface  
Lip-handle lid  
Axle bearing in the stack at the edge of container

## OPTIONS:

Recycling inserts for PET, paper, packaging and glass  
Foot pedal  
Chip nest  
Locking system  
Noise reduction  
Marking  
Hot stamping  
Colors: green, yellow, blue, dark grey, red, brown



Other colors on request.

## ADVANTAGES OF HDPE MATERIAL:

Environment friendly  
Long life expectancy  
Can be recycled  
Frost-proof  
Chemical resistance  
High UV light resistance

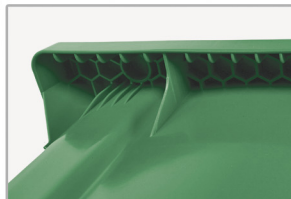

## DIMENSIONS:

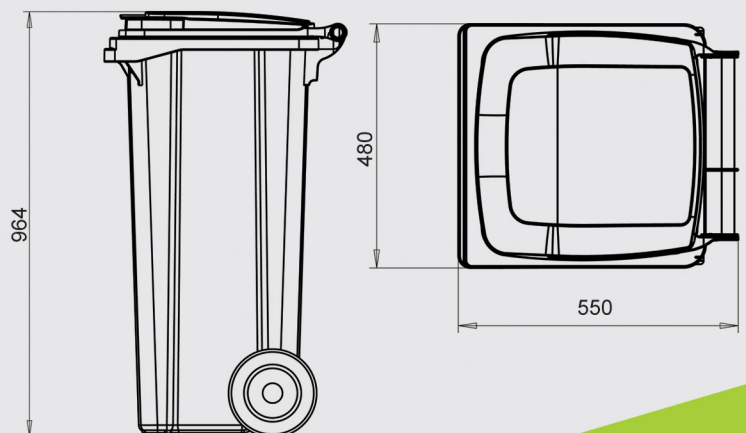

EN 840

